

R Series



CANATAL - A NAME YOU CAN TRUST FOR ALL YOUR PRECISION AIR CONDITIONING NEEDS

PRECISION COOLING SYSTEMS R SERIES

CAPACITY : 20kW to 60kW

CANATAL R Series systems feature highly efficient rack in-row cooling and uniform temperature and air distribution, especially suited for cold or hot aisle containment environment. The R series are available in cooling configurations of air cooled, water cooled and chilled water, for precise cooling and humidity control, ensuring reliability and efficiency in the 24/7 operation within the highly sensitive environment. Built with advanced control systems, these systems readily adapt to rapid changing heat load and improve on system reliability through real time monitoring, to effectively save energy. Suited for rapid deployment and expansion, these compact floor standing units support up to 5 modules with configurable unit and fans running program to achieve higher efficiency and extending the equipment lifespan. These units are tested to increase cooling efficiency of up to 20%, ensuring better PUE and energy savings.

CANATAL R Series is specially developed for precise environmental control applications :

- > Data Centres / Server Farms
- > Telecommunications facilities
- > Server Rooms



FEATURES & BENEFITS

- > **Rack level EC fans** with synchronized, horizontal side throw air distribution, achieving low air flow resistance
- > **Automatic Variable Speed controls** for optimal air volume control
- > **Electronic Expansion Valves** automatically adjust according to heat load requirements
- > **Uphrow or downthrow air configuration.** Downthrow underfloor fan for optimized air distribution
- > **Cold or hot aisle system configuration** to suit to different operating environment
- > **Intelligent Microprocessor Controller** enables central control at containment level
- > **Co-Work™** Dynamic Network for co-ordinated and backup controls
- > **R410A** environmental friendly refrigerant
- > Options for DC inverter scroll compressor

TECHNICAL DATA
R SERIES - AIR-COOLED SYSTEM (INVERTER TYPE - R410A)

Model (R**A)		020	025	035	040	050
Cooling Capacity - DB37°C, 30%RH						
Total Cooling Capacity	kW	21.5	26.5	36.1	41.1	50.1
Sensible Cooling Capacity	kW	20.6	25.4	34.7	39.5	48.1
Indoor Fan - Backward Curved EC Fan						
Air volume	m ³ /h	4500	5200	8000	9000	11500
Power	kW	1.36	1.19	2.5	2.5	2.5
Standard External Pressure	Pa	20	20	20	20	20
Scroll Compressor						
Power	kW	6.2	7.8	14.1	14.1	18.2
Compressor Quantity	No.	1	1	1	1	1
Heater – PTC Heater (Optional)						
Power	kW	6	6	9	9	9
Electrode Steam Humidifier (Optional)						
Humidification Amount	kg/h	3	3	3	3	3
Power	kW	2.0	2.0	2.0	2.0	2.0
Air filter - EN799, Efficiency 90%, G4						
Filter Quantity	No.	2	2	2	2	2
Pipe Connection Size						
Liquid Pipe	mm	16	16	16	16	16
Exhaust Pipe	mm	19	22	28	28	28
Humidifier Inlet Pipe	mm	6	6	6	6	6
Drain Pipe	mm	25	25	25	25	25
Outdoor Condenser – Adjustable according to condensing pressure						
Model		NACD12J	NACD18	NACD22	NACD26	NACD30
Condenser Quantity	No.	1	1	1	1	1
Electrical Parameters - Power Supply Parameters – 380V-420V, 50Hz						
Full load current	A	32	33	44	44	50
Noise : Measured at 1.5m from the front of the unit						
Noise	dB(A)	65	69	69	69	69
Dimensions & Weight						
Length x Width x Height	mm	300 x 1200 x 2200			600 x 1200 x 2000	
Weight	kg	300	300	350	380	400

- Please contact our representatives for other requirements.
- The manufacturer reserves the rights to make changes to the product specifications. The data shown above may vary.

TECHNICAL DATA
R SERIES - CHILLED WATER SYSTEM

Model (GAD/U**)		025	035	040	050
Cooling Capacity - DB37°C, 30%RH – Inlet Water Temp 7°C, Outlet Water Temp 12°C					
Total Cooling Capacity	kW	30.1	41.5	51.8	75.7
Sensible Cooling Capacity	kW	25.3	33.5	48.1	66.4
Chilled Water Flow Rate	l/s	1.4	2.0	2.5	3.6
Pressure Drop	kPa	<60	<80	<55	<80
Cooling Capacity - DB37°C, 30%RH – Inlet Water Temp 10°C, Outlet Water Temp 15°C					
Total Cooling Capacity	kW	26.8	32.7	42.3	59.3
Sensible Cooling Capacity	kW	26.8	32.7	42.3	59.3
Chilled Water Flow Rate	l/s	1.3	1.6	2.0	2.8
Pressure Drop	kPa	<60	<80	<55	<80
Cooling Capacity - DB37°C, 30%RH – Inlet Water Temp 12°C, Outlet Water Temp 18°C					
Total Cooling Capacity	kW	25.2	29.3	36.3	51.9
Sensible Cooling Capacity	kW	25.2	29.3	36.3	51.9
Chilled Water Flow Rate	l/s	1.2	1.4	1.7	2.5
Pressure Drop	kPa	<60	<60	<55	<55
Cooling Capacity - DB38°C, 30%RH – Inlet Water Temp 15°C, Outlet Water Temp 21°C					
Total Cooling Capacity	kW	22.9	26.4	32.9	47.3
Sensible Cooling Capacity	kW	22.9	26.4	32.9	47.3
Chilled Water Flow Rate	l/s	1.1	1.3	1.6	2.3
Pressure Drop	kPa	<60	<60	<55	<70
Cooling Capacity - DB24°C, 50%RH – Inlet Water Temp 7°C, Outlet Water Temp 12°C					
Total Cooling Capacity	kW	15.6	20.5	27.9	35.4
Sensible Cooling Capacity	kW	13.1	17.3	26.0	33.1
Chilled Water Flow Rate	l/s	0.7	1.0	1.2	1.7
Pressure Drop	kPa	<40	<50	<55	<55
Indoor Fan - Backward Curved EC Fan					
Air Volume	m ³ /h	4500	5200	9520	11500
Power	kW	1.2	1.2	3.75	3.75
External Static Pressure	Pa	20	20	20	20
Air Filter – EN799, Efficiency 90%, G4					
Filter Quantity	No.	2	2	1	1
Heater – PTC Heater (Optional)					
Power	kW	6	6	9	9
Current	A	9.1	9.1	13.6	13.6
Electrode Steam Humidification (Optional)					
Humidification Volume	kg/h	3	3	3	3
Power	kW	2.0	2.0	2.0	2.0
Noise - Measured at a distance of 1.5m from front of unit					
Noise	db(A)	65	65	69	69
Chilled Water Valve : Two Way Valve					
2-Way Valve Size	mm	32	32	40	40
Pipe Connection Size					
Chilled Water Inlet Water Pipe	mm	32	32	40	40
Humidifier Inlet Pipe	mm	6	6	6	6
Drain Pipe	mm	25	25	25	25
Electrical Parameters – 380V-420V, 50Hz					
Full Load Current	A	14.7	17.6	24.0	24.0
Dimensions & Weight					
Length x Depth x Height	mm	300 x 1200 x 2200		600 x 1200 x 2200	
Weight	kg	150	155	300	350

- Please contact our representatives for other requirements.
- The manufacturer reserves the rights to make changes to the product specifications. The data shown above may vary.

DIMENSION SPECIFICATIONS R SERIES - OUTDOOR CONDENSER

NACD18/22

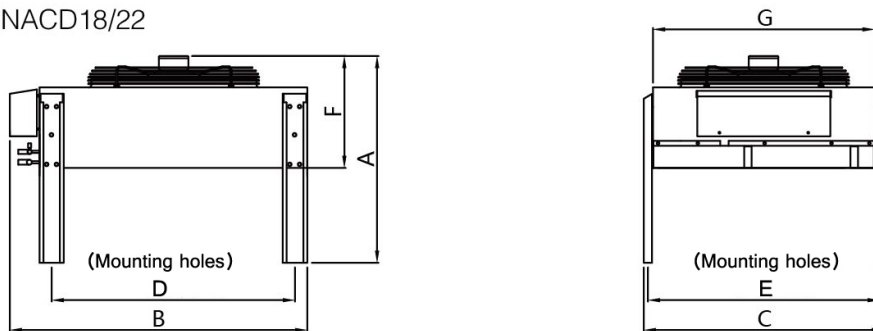

NACD26/30/34

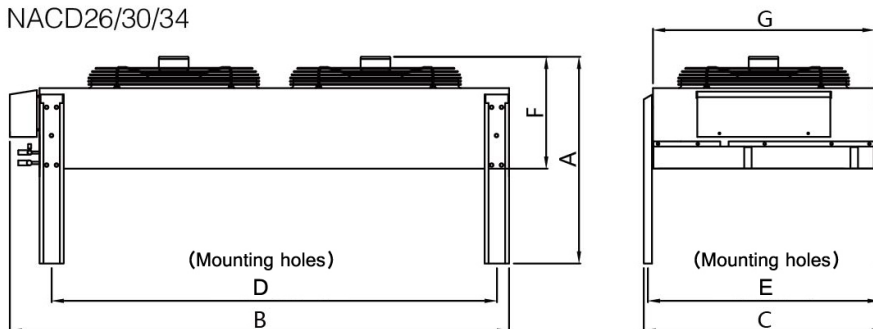

NACD12J

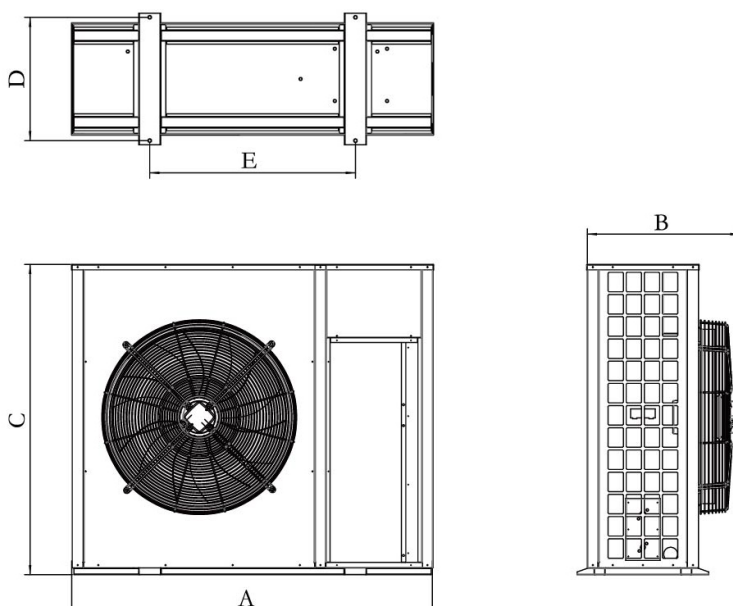

Model	A	B	C	D	E	F	G	Power Supply	Power (kW)	Weight (kg)	Noise (db(A))
NACD18	1092	1475	1235	1272	1196	616	1155	220V ±15%, 1Ø ~50Hz	0.63	115	65
NACD22	1144	1475	1235	1272	1196	668	1155	380V ±15%, 3Ø ~50Hz	1.05	135	65
NACD26	1092	2070	1235	1867	1196	616	1155	220V ±15%, 1Ø ~50Hz	1.26	165	65
NACD30	1104	2070	1235	1867	1196	628	1155	380V ±15%, 3Ø ~50Hz	1.88	1.95	65
NACD05J	790	355	1228	388	534	/	/	220V ±15%, 1Ø ~50Hz	0.3	65	50
NACD12J	1320	560	1140	450	750	/	/	220V ±15%, 1Ø ~50Hz	0.57	90	55